



THE MOST ADVANCED DESICCANT TECHNOLOGIES
FOR PRECISE MICROCLIMATE CONTROL



STANDARDS

The equipment comply to all of the applicable US,CA&EU directives and regulations.



MADE IN EUROPE

All components made exclusively by European manufacturers.



VAST EXPERIENCE

Practical experience in the desiccant dehumidification more than 15 years.



TECHNICAL DATASHEET

Desiccant dehumidifier MDC 1000

GENERAL INFORMATION

Desiccant dehumidifier MDC 1000 designed for general purposes – room air dehumidification and process drying. The compact construction allows extended periods of operation with a minimum of maintenance. Especially suitable for low temperature

and low humidity operation. Unit includes desiccant rotor, EC-fans, reactivation PTC-heater, filters and controls.

In addition to above mentioned application, desiccant dehumidifiers are irreplaceable in:



Protecting against window condensation and glass ceiling in the administrative as well as residential buildings.



Improving the quality of the finishing works during apartment repairs due to drying without thermal movements in the covering products used for walls, floor and ceiling.



Elimination of the effects of the floods, drying new buildings.



Increasing the shelf life of hygroscopic materials: medicines, detergents, building materials and other bulk materials.



Maintaining a low level of humidity during the production of food items as well as products made of wood, rubber and plastic, during the manufacture of furs.



Maintaining the marketable condition of clothing and packaging items.



Reducing the growth of bacteria, etc.

METHOD OF OPERATION

A desiccant dehumidifier removes water from a flow of the air that passes through it. The heart of this process is an adsorption rotor coated with a special substance that absorbs the water molecules that make up the moisture in the passing air (Process air). When saturated, the rotor is rotated over to a

regeneration zone, where it is dried with heated air (Reactivation air). The warm, humid regeneration air is led away out of the unit (Wet air) and the rotor is once again ready to absorb water molecules.

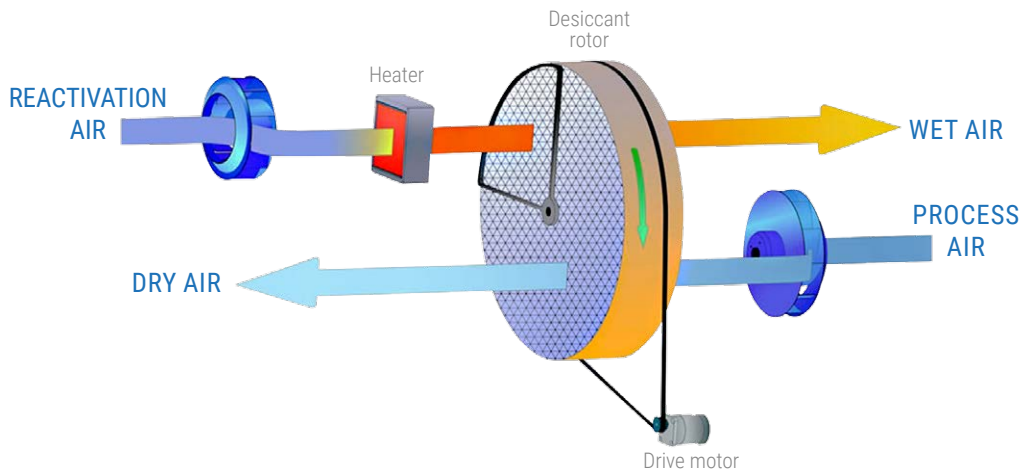

CONSTRUCTIONAL FEATURES

- The casing has high resistance to atmospheric corrosion and made of 1,0 mm stainless steel sheet metal; some parts made of 1,5 and 2,0 mm stainless steel in order to achieve rigidity. Insulation – 20mm;
- Compact design and low weight of the unit;
- High performance at low temperatures and low relative humidity in a room;
- Optional humidistat is available as an accessory;
- Microprocessor based control (option);
- Easy access to the internal components of the dehumidifier for the maintenance;
- EC-fans;
- PTC-heater;
- High efficiency of the washable silica gel rotor;
- All components made exclusively by European manufacturers.

TECHNICAL DATA

Process air		
Rated airflow	600 CFM	(1000 m ³ /h)
Available static pressure	0.8 " wc	(200 Pa)
Reactivation air		
Rated airflow	235 CFM	(400 m ³ /h)
Available static pressure	1.1 " wc	(280 Pa)
Power supply		
(3x480V, 60 Hz)	13 kW	
Current	19 A	

Miscellaneous data		
Dehumidification capacity (at 68°F (20 °C), 60%RH)	16.76 lb/h	(7,6 kg/h)
Weight	342 lbs	(155 kg)
Operating temperature	-22/+104°F (-30/40°C)	
Max noise level without ductworks	70 dBA	
Air filter	MERV7	
IEC protective class	NEMA3	
Insulation	0,79" (20 mm)	

DEHUMIDIFICATION CAPACITY

	50%	60%	70%	80%	90%
41°F (5°C)	6,61(3,0)	7,94(3,6)	9,04(4,1)	10,14(4,6)	11,46(5,2)
50°F (10°C)	9,26(4,2)	10,80(4,9)	12,24(5,55)	13,78(6,25)	15,21(6,9)
68°F (20°C)	14,77(6,7)	16,76(7,6)	17,64(8,0)	18,74(8,5)	19,51(8,85)
86°F (30°C)	17,64(8,0)	18,30(8,3)	18,74(8,5)	19,22(8,72)	19,84(9)

Approximate capacity in lb/h (kg/h) at different inlet process air relative humidity (%) and temperature (°C)

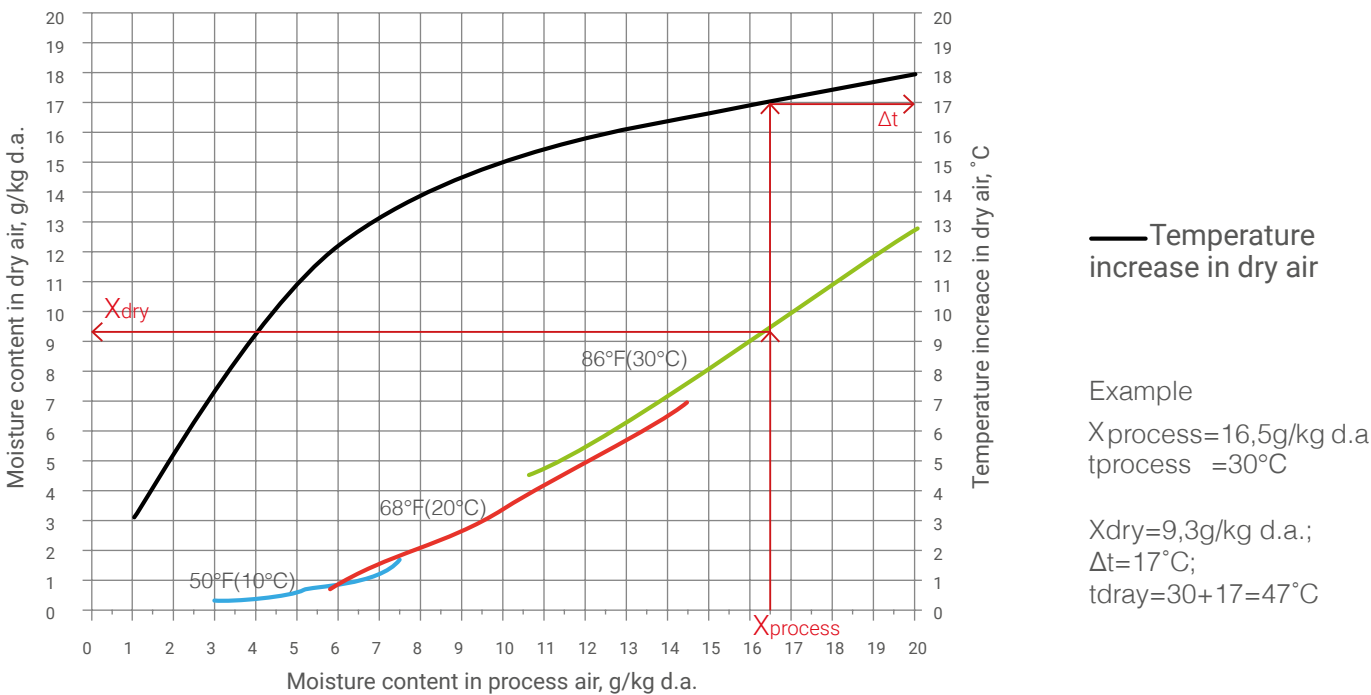

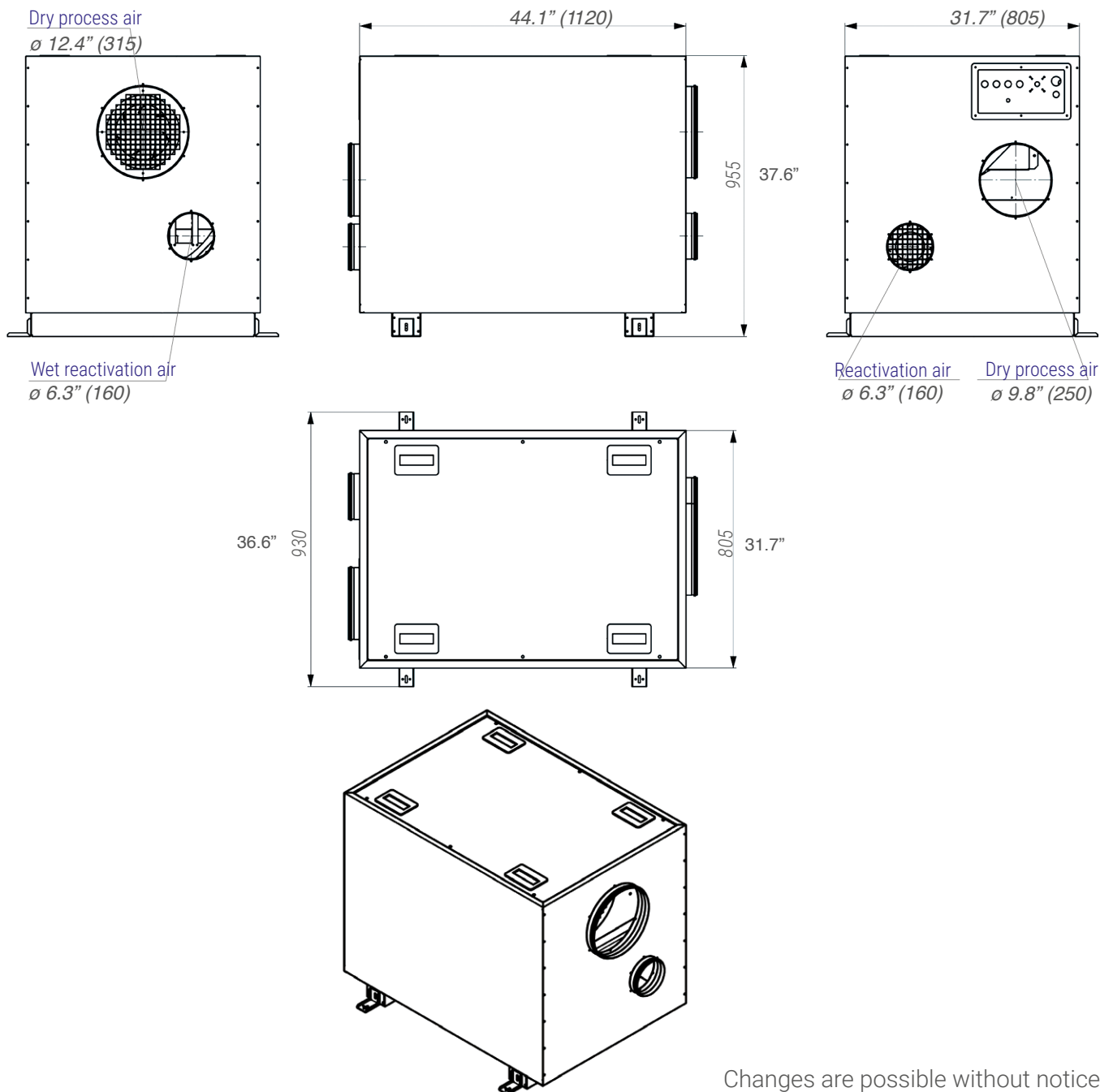

Changes are possible without notice.



UAB DESICCANT TECHNOLOGIES GROUP

E-mail: info@visionaq.com Ph.: +1 825 925 56 55 www.visionaq.com